

DYNAMIC
PROJECTION
INSTITUTE

ULS Mirror



The ULS Mirror is a high-quality static mirror system developed and produced by Dynamic Projection Institute in Austria.

Designed for maximum flexibility, it enables precise redirection of projections onto virtually any surface – even in confined or architecturally challenging spaces.

Equipped with a front surface mirror with outstanding visual clarity. All static components are crafted from lightweight, black anodized aluminium.

Whether in immersive installations, museums, auditoriums, events, or retail spaces, the ULS Mirror unlocks new projection possibilities wherever ceiling height or viewing angles are limited – or where projectors need to be mounted discreetly and elegantly, without the need for complex mounting structures or custom-built rigs.

ULS Mirror

The ULS Mirror is extendable to any projector and with a single handle, the mirror position can easily be changed or adjusted. It can be mounted directly to the projector and with various supports very tight onto ceilings, walls, trusses, or mobile stands.

In most cases with the 3-chip projectors, the throw ratio can go down until 0.56:1 and with 1-chip projectors it can be lower. It works with standard and long throw lenses as well.

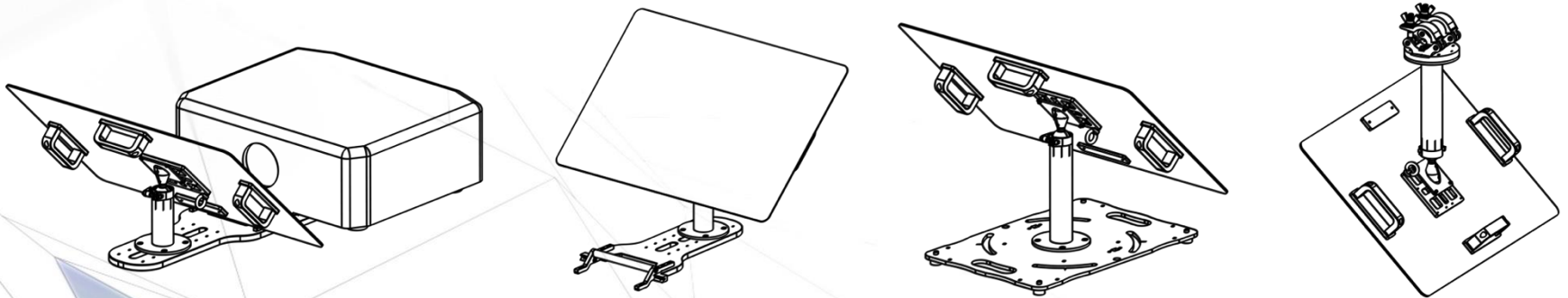

ULS Mirror Set + Projector Plate

- The most commonly used version of the ULS Mirror
- Allows direct mounting to virtually any projector
- Supports various mounting configurations
- Can be used with or without a frame
- Suitable for a wide range of installation scenarios

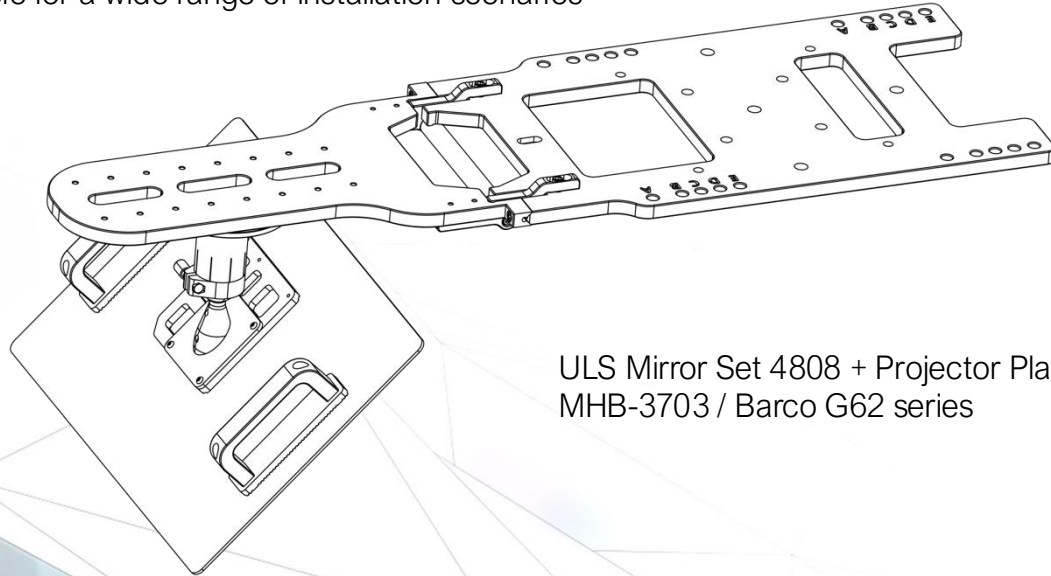

ULS Mirror Set 4808 + Projector Plate
MHB-3703 / Barco G62 series

ULS Mirror Set + Projector Plate

- Exception: Barco QDX, UDX, UDM & HDX Series
- Projector Plate is mounted on the frame in front of the optics, not directly on the projector
- Frame is mandatory for this variant

ULS Mirror Set 4808 + Projector Plate MHB-2901 / Barco UDM

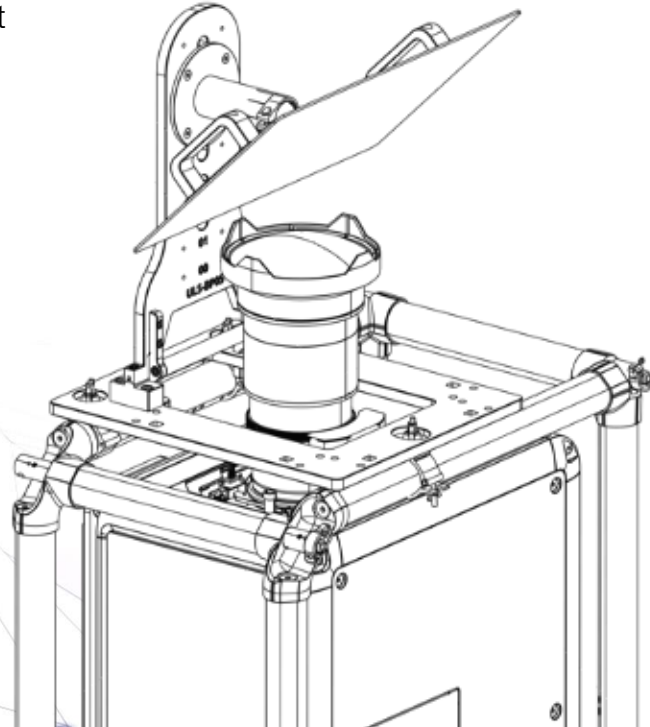

ULS Mirror

The ULS Mirror is available in three standard sizes, depending on the lens throw ratio and the required mirror deflection angle. Custom mirror sizes can also be manufactured on request.

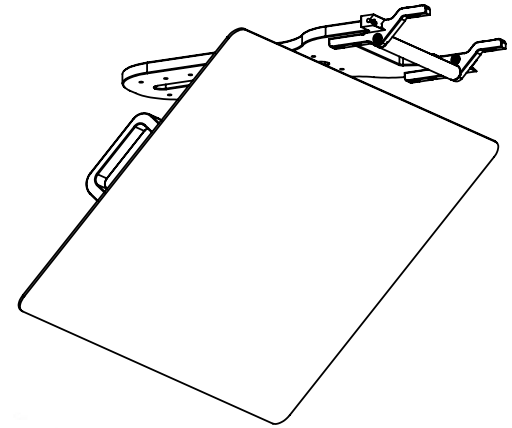
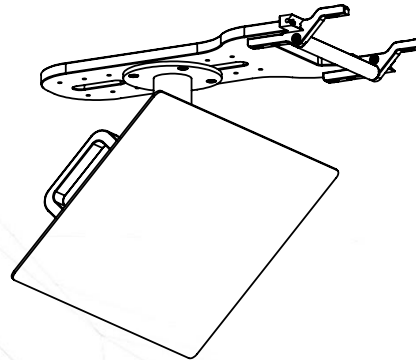
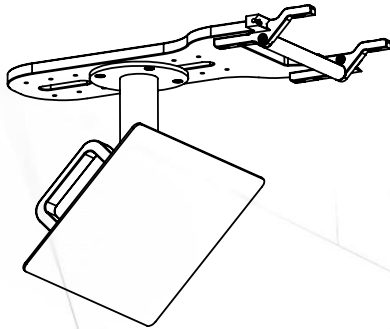

ULS Mirror

Expand integration possibilities by enabling projection from unconventional angles and allowing flexible mounting options. The most common configurations, of course, are 90° vertical and 90° horizontal deflection.

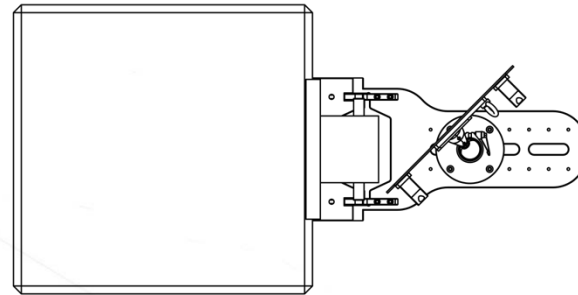
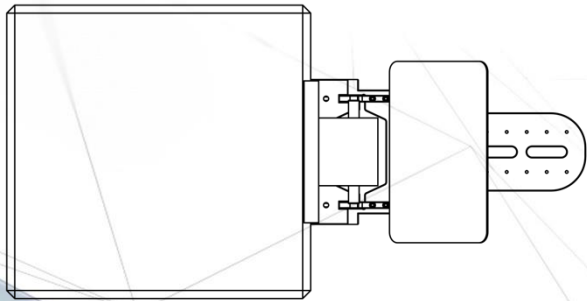
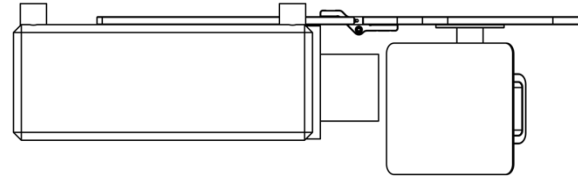
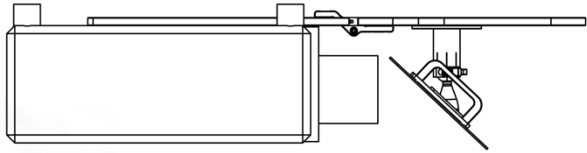

Projector Plate

Versatile Mounting Options: The Projector Plate comes equipped with multiple internal threads, allowing you to attach half couplers or other mounting accessories effortlessly. This feature ensures compatibility with various truss and pipe configurations, providing flexibility for your setup.

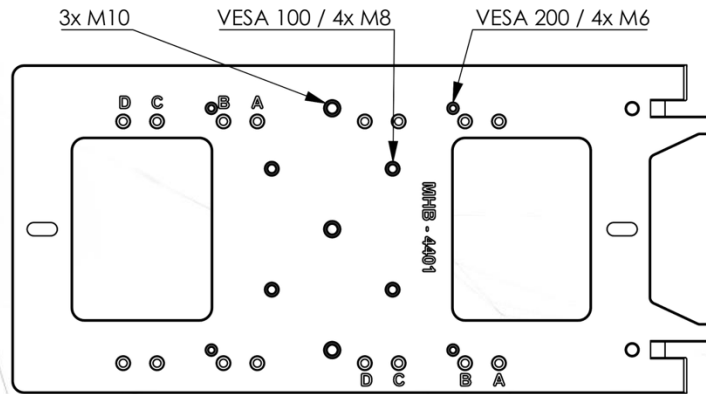

Projector Plate MHB-4401 for the Barco i600 projectors

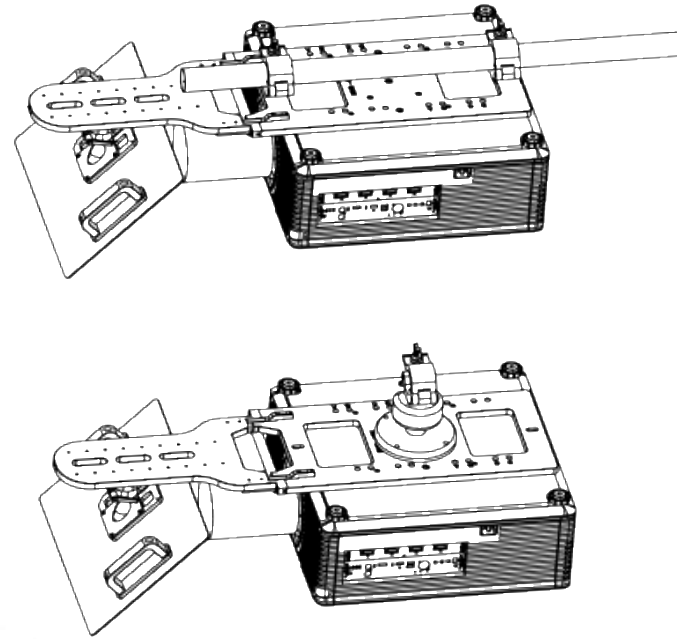

ULS Mirror – Ceiling Mount & Vertical center

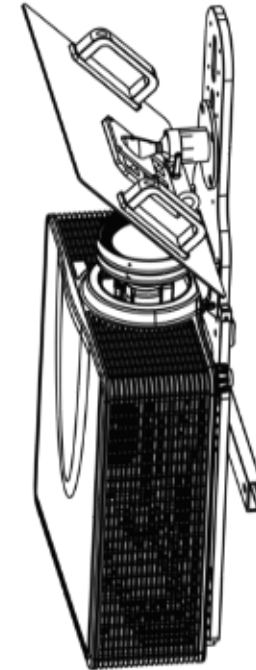
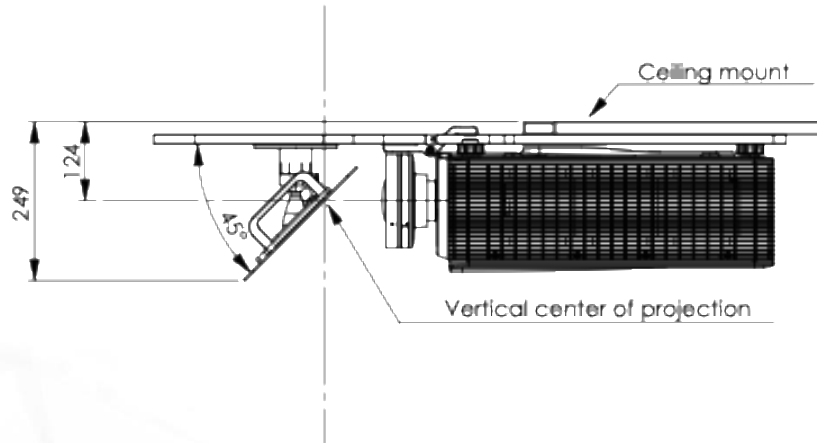

The ULS Mirror is frame-compatible but not necessarily required. A specially developed Ceiling Mount allows installation with an extremely minimal distance to the ceiling or wall.

Vertical center of projection indicates the vertical center of the image, and from that point to the projection plane is the projection distance, which is used to calculate the image size.

ULS Mirror – Some mounting options.

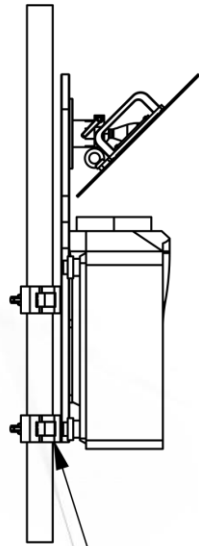

Half Coupler

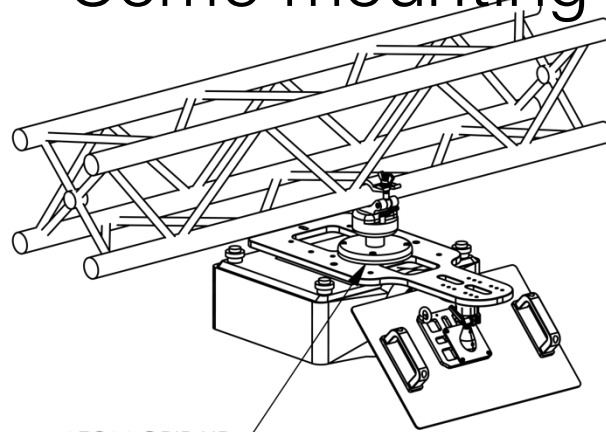

ATOM GRIP HD

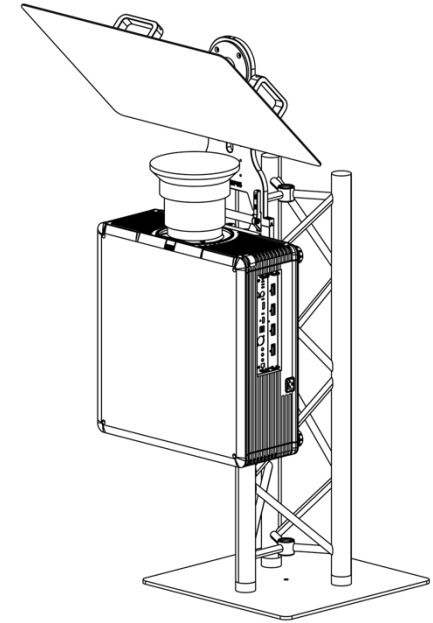
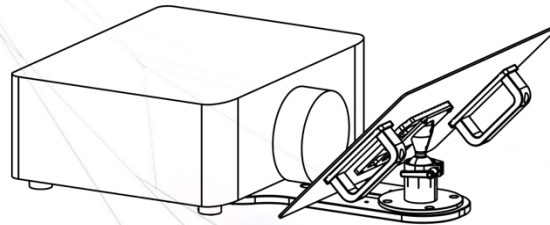

The smart replacement for L-lenses.

With ULS Mirrors as a smart alternative to L-lenses, the projectors can simply be mounted vertically, optionally placed on platforms, to match the projection height instead of being suspended from trusses.

This reduces structural complexity, minimizes installation effort both in terms of construction and manpower (no need to lift projectors to great heights), and creates a clean, flexible, and architecturally integrated setup.

The ULS Mirror ensures precise alignment, optimal use of space, and a minimal visual footprint.

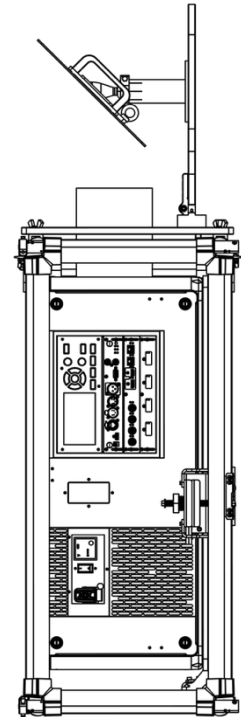
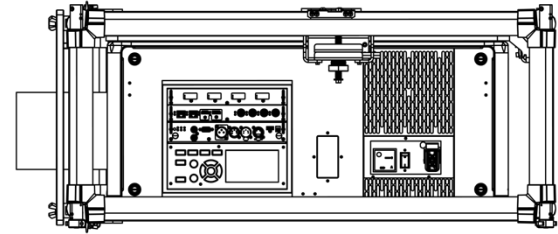

ULS Mirror Set 4813

When ceiling space is tight.

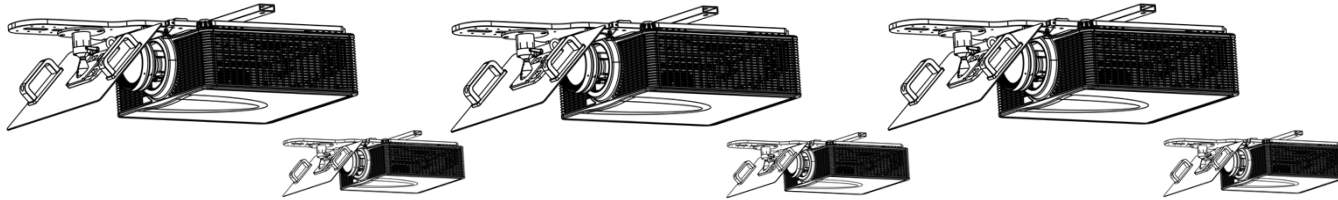

Who hasn't faced this? Often, ceiling height doesn't match the scale of modern venues – yet these spaces offer authenticity, character, and exactly what the client wants.

Many projection setups cannot be realised because conventional projector mounting for floor projections leaves too little headroom. This often makes it uncomfortable for visitors to walk through the installation.

By combining projectors with the ULS Mirror, projection distance can be increased while saving headroom. This allows the use of longer focal length lenses, improving image quality, reducing shadows, and enhancing both visitor comfort and installation flexibility.

Positioning projectors close to the ceiling or wall offers a cleaner, more refined look. In the end, it's the message and experience of the installation that should take centre stage – not the hardware.

When ceiling space is tight.

The illustration shows 10k 1-chip projectors with a throw ratio of 0.6:1 in a room with a ceiling height limited to 3 meter.

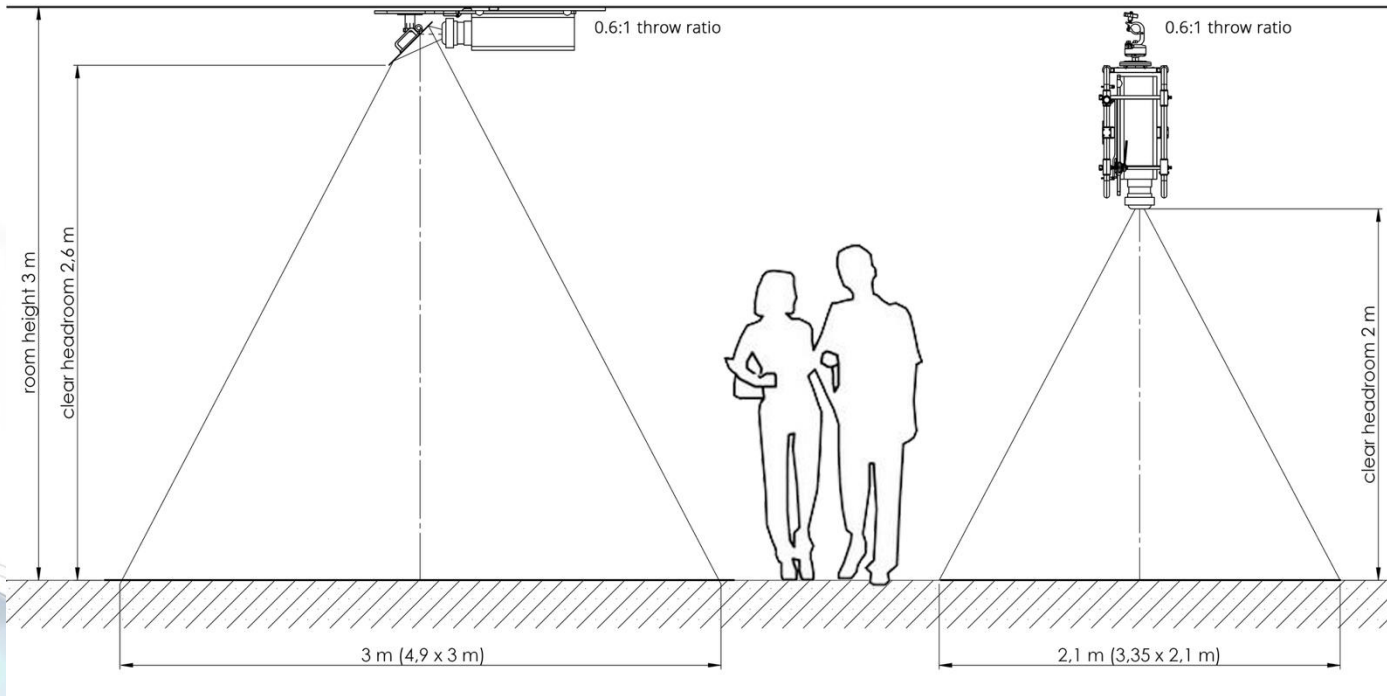











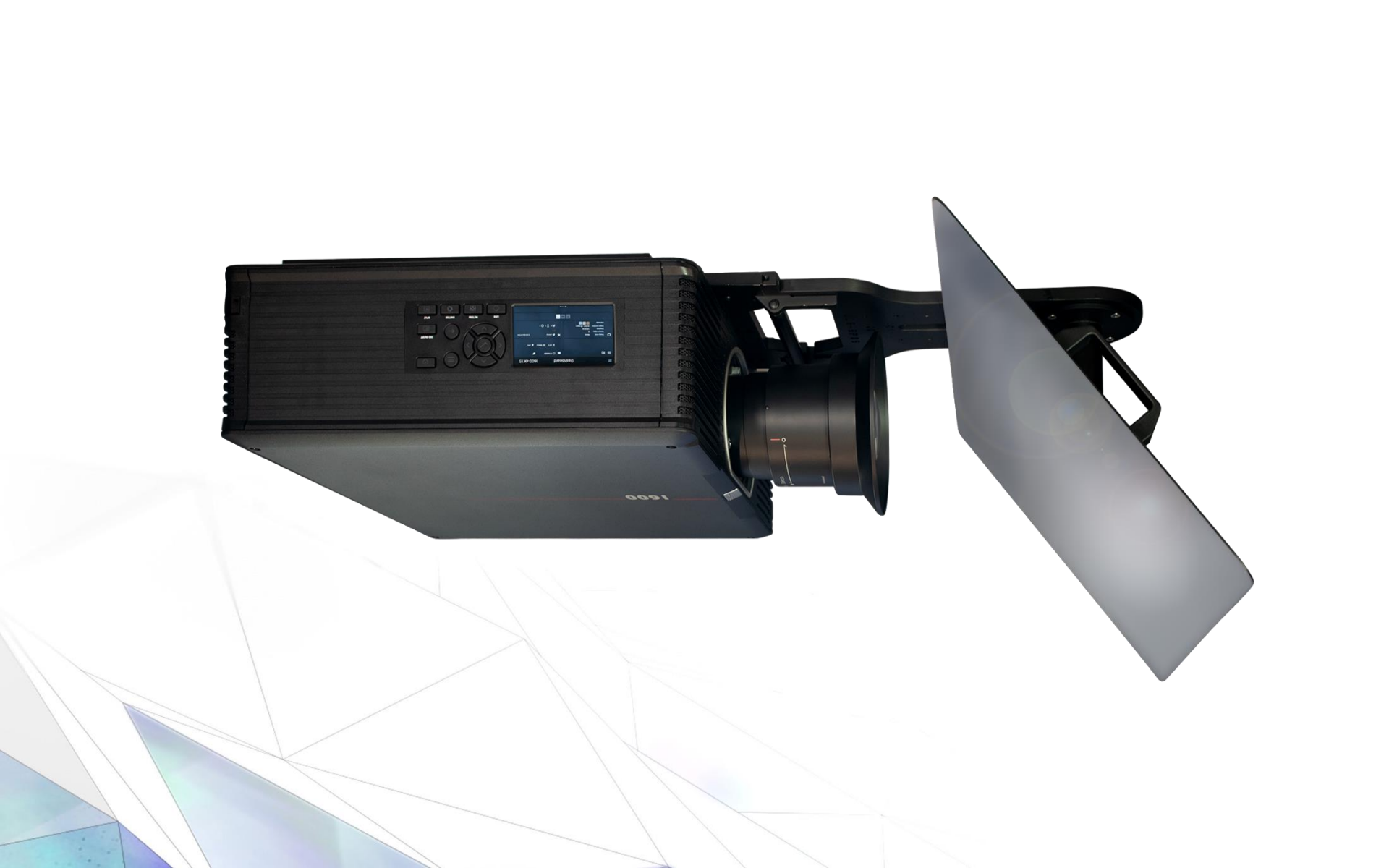







G100

BARCO

Compatibility

The ULS Mirror is compatible with nearly all Barco projectors and lenses with a throw ratio above 0.54:1, depending on the image chip size, which must be verified in each case. If a model is not yet included in our product range, we can develop a custom-built ULS Mirror solution. The system is highly flexible and only requires specific projector mounting plates.

Already available for the following models:

- Barco QDX, UDX, UDM, HDX Series
- Barco F70, F80, F90 Series
- Barco G50, G52, G60, G62, G100 Series
- Barco i600 Series

50 Songs of the Sea.

For Zara's 50th anniversary, the iconic viewpoint on Monte de San Pedro in A Coruña was transformed into a captivating immersive installation – drawing visitors into a luminous visual poem.

Inside the 25-meter dome, 14 three-chip projectors with standard zoom lenses brought the space to life. By using M340 ULS Mirrors as smart alternatives to L-lenses, the projectors could be elegantly concealed and vertically mounted, ensuring a seamless and breathtaking visual experience.



50 Years of the Sea – Credits

- Artist and Designer: Es Devlin
- Producers: LarMac & Es Devlin Studio
- Auditoria: Spatial audio system & show control
- Polyphonia: Music & sound design
- VYV: Video systems (vyv.ca)
- WonderWorks: Technical implementation

Watch the video: <https://youtu.be/ld0gMPxlgMg>

Immersion without Limits.

“Forces of Nature” at InfoComm India 2024 delivered a fully immersive journey with four-sided projection, ambisonic sound, and interactive floor content – capturing both serenity and intensity of nature.

Powered by 14 projectors mapped with PIXERA, SPAT audio, and TouchDesigner, ULS Mirrors enabled discreet placement, longer throws, and seamless integration.



Forces of Nature – Credits

- Presented at InfoComm India 2024 by AVIXA
- Installation: MSS World India & Studio Ocupus
- Immersive sound design: FLUX:: Immersive

Video: <https://www.youtube.com/shorts/B9OZPp0BALg>



A Mirror to the Earth.

“Save Land. United for Land” is an immersive exhibition developed with the UNCCD-G20 Global Land Initiative. It brings together contemporary art, science, and media technology to raise awareness about the global condition of our soils. Interactive 4K floor projections stress the urgent need to protect and restore soils. Custom-built ULS Mirrors enabled ultra-short-distance ceiling projection, allowing projectors to mount discreetly near the ceiling and blend seamlessly into the architecture rather than hanging like foreign objects in the space.



Save Land. United for Land – Credits

- Venue: Bundeskunsthalle Bonn
- Curator: Dr. Henriette Pleiger
- Concept & Design: dform GmbH
- Interactive Installations: Bildwerk Media OG

ULS@ Saudi Light & Sound Expo 2025.

At the Saudi Light & Sound Expo 2025 in Riyadh, Martin Professional Middle East - our trusted distribution partner in the CGG region – showcased the ULS Mirror as a key component of their main projection feature. Instead of relying on large-scale suspended truss systems, projectors were mounted on a raised platform and redirected using our ULS Mirror. This approach not only reduced structural complexity but allowed for a clean, flexible, and architecturally integrated projection setup – perfectly suited for high-profile trade show environments.



SLS Expo 2025 – Credits

- Event: Saudi Light & Sound Expo 2025, Riyadh
- Booth concept: Martin Professional ME
- Installation: Martin Professional ME

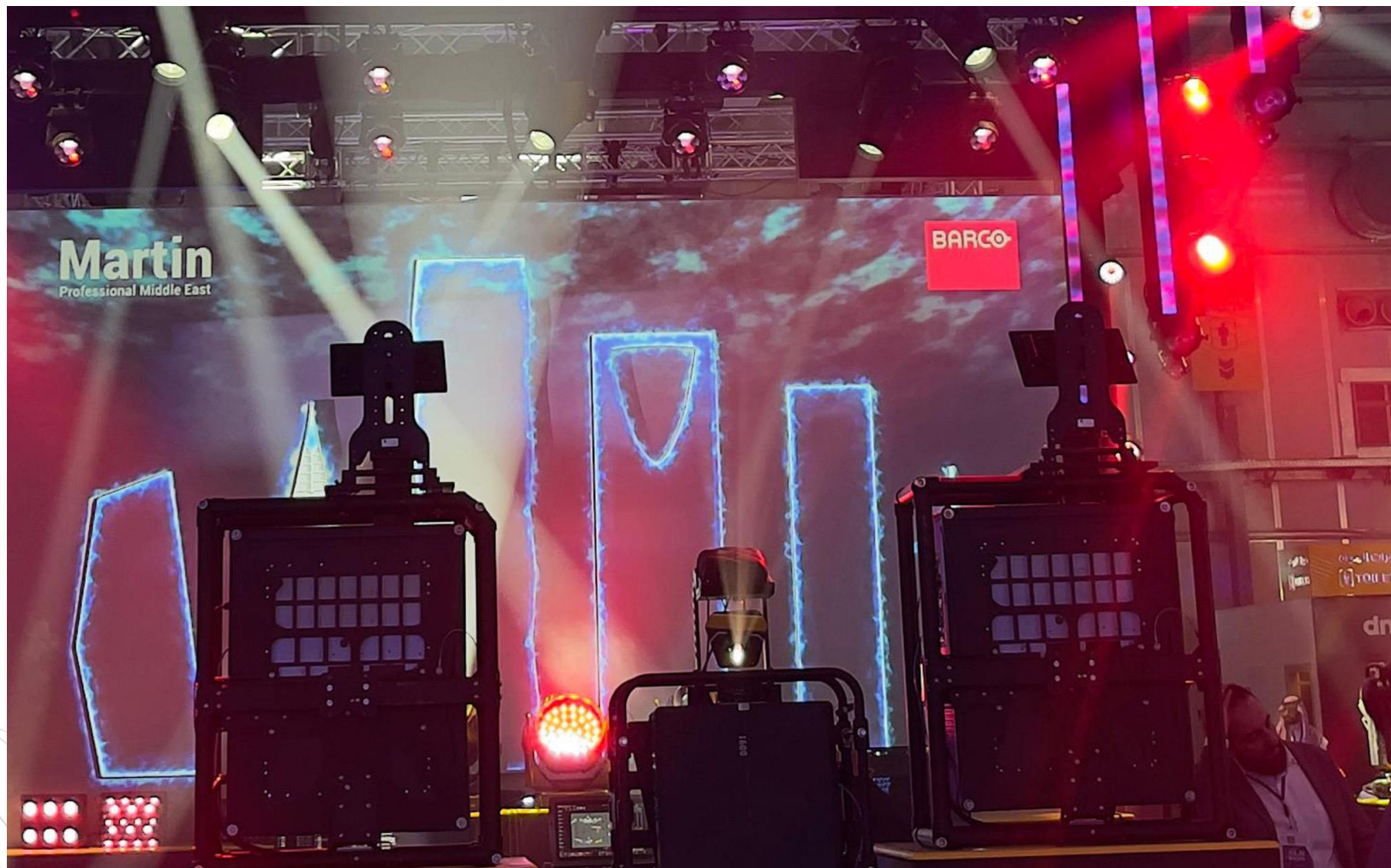

Experience Mozart like never before.

At the “Mythos Mozart” immersive experience in Vienna, visitors can now get a glimpse of Mozart’s life in a unique way that combines music, architecture, performing arts and technology in an unforgettable multimedia installation. In one of the rooms, six ULS Mirrors in combination with 3-chip projectors equipped with short-throw lenses cover the entire floor of a very low basement space, completing the immersive installation where artificial intelligence creates fantastic new visual worlds to the sounds of the Magic Flute, based on images and millions of data points about Mozart.

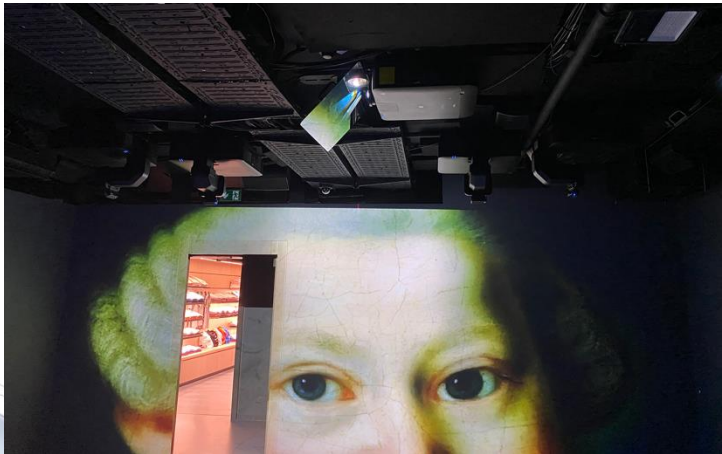

Mythos Mozart – Credits

- Venue: STEFFL department store Vienna
- Curator: Christopher Widauer
- New media artist: Refik Anado
- Music & Sound design: Walter Werzowa
- General technical service provider: PKE





A logical upgrade
for projectors.



About the Manufacturer

Dynamic Projection Institute GmbH is an Austrian company that develops state-of-the-art video projection technology. With the Mirror Head and ULS Mirror add-ons, users can easily adjust projection positions digitally or manually, enabling impactful installations and flexible projector placement.



A close-up photograph of a camera lens assembly. In the foreground, a dark metal bracket is partially visible, featuring the Dynamic Projection Institute logo and name. The background shows the intricate glass elements of the lens, with some elements reflecting light in vibrant colors like green, blue, and red.

DYNAMIC PROJECTION
INSTITUTE



Contact us

Dynamic Projection Institute GmbH

Tel: +43 1 996 2028 0

office@dynamicprojection.com

www.dynamicprojection.com